



## RCA MANUFACTURING COMPANY, INC.

A RADIO CORPORATION OF AMERICA SUBSIDIARY

*Harrison, New Jersey*

RCA RADIOTRON  
D I V I S I O N

APPLICATION NOTE No. 73  
March 31, 1937

### APPLICATION NOTE ON OPERATION OF THE 25L6 IN TYPICAL CIRCUITS

The 25L6 is a beam power amplifier tube designed primarily for use in transformerless a-c/d-c receivers. Outstanding features of this tube are high plate-circuit efficiency, high power sensitivity, and high power output at the comparatively low plate and screen voltages available for a-c/d-c receivers. For example, under ideal conditions, with 110 volts applied to plate and screen of a single 25L6, more than 2 watts at reasonable distortion can be obtained at the grid-current point; a peak signal of only 7.5 volts is required for this output.

The internal construction of the 25L6 is similar to that of the 6L6-- both tube types utilize directed electron beams to suppress secondary electrons from the plate. This feature accounts for the high plate-circuit efficiency and high power sensitivity of beam-type output tubes.

The high power sensitivity of the 25L6 permits its use in sensitive, low-cost circuits. A single 25L6 can be driven to rated output by: (1) a single 6Q7 used as a second detector and first a-f amplifier, (2) a 6J7 used as a biased detector, (3) a 6F7 used as an i-f amplifier and biased detector, and (4) a 6C5 used as a biased detector. This Note describes the operation of the 25L6 in typical circuits which use these tube types.

#### Typical A-C/D-C Power-Supply Unit

The circuit of the power-supply unit used in these tests is shown in Fig. 1. In this power unit,  $R_1$  is the series heater resistor;  $R_2$  represents the resistance of the speaker field;  $R_3$  is a resistor which represents the load of one or more r-f or i-f tubes; and  $R_4$  and  $R_5$  are resistors used to obtain bias voltages from the voltage drop across the filter choke, which is connected in the negative side of the line.

This method of obtaining bias, called the choke-bias method in this Note, has two important advantages. (1) The full output voltage of the power-supply unit is available for plate and screen voltage. When the choke is connected in the positive side of the line and bias is obtained by some other method, plate and screen voltages are necessarily decreased

Copyright, 1937, by  
RCA Manufacturing Co., Inc.

AN-73-3-19-37  
Printed in U.S.A.

*RCA Cunningham • Radiotron Radio Tubes • RCA Radiotron Transmitting Tubes • Special Purpose Tubes • Photo Tubes • Cathode Ray Tubes  
Genuine RCA Replacement Parts, Accessories and Test Equipment*

A P P L I C A T I O N N O T E S



by an amount equal to the bias. In an a-c/d-c receiver, this decrease in voltage may cause an appreciable loss in power output. (2) Bias is obtained at low cost. Other methods of obtaining bias may require the use of at least one resistor and a high-capacity by-pass condenser; the suggested arrangement requires only two resistors and a low-capacity by-pass condenser. However, to complete the data in this Note, tests were also made with the conventional self-bias circuit; in all self-bias tests, the choke was connected in the positive side of the line.

In a-c/d-c receivers the input-filter condenser ( $C_1$ ) generally is either 40  $\mu\text{f}$  or 24  $\mu\text{f}$ . Data presented in this Note are for these two values of  $C_1$ . A low-cost filter choke was used; its d-c resistance was 200 ohms and the coil was wound on a 5/8" x 5/8" core. All tests were made at a line voltage of 117 volts (rms).

### 1. Arrangement Using 6Q7 (A-F Amplifier) and 25L6 (Choke Bias)

In the test of this arrangement, an a-f signal was fed to the grid of a 6Q7; the output of the 6Q7 was resistance-coupled to a 25L6. The bias for each tube was obtained from the voltage drop across the filter choke, which was connected in the negative side of the line, as shown in Fig. 1. The circuit and operating characteristics of the amplifier are shown in Fig. 2 for the following conditions: (1)  $C_1 = 40 \mu\text{f}$  and  $R_3 = 50000$  ohms; (2)  $C_1 = 40 \mu\text{f}$  and  $R_3 = 9750$  ohms; (3)  $C_1 = 24 \mu\text{f}$  and  $R_3 = 50000$  ohms; and (4)  $C_1 = 24 \mu\text{f}$  and  $R_3 = 9750$  ohms. The curves corresponding to  $R_3 = 9750$  ohms depict operation of the receiver when a weak carrier is tuned in and sufficient audio signal is available to drive the 25L6 to rated output. The value of  $R_3 = 9750$  ohms represents the load on the power unit when a converter and i-f stage operate at normal voltages.

The value of  $R_3 = 50000$  ohms represents the load on the power-supply unit when a converter and an i-f stage are nearly cut off by the a-v-c voltage. Thus, the curves corresponding to  $R_3 = 50000$  ohms depict operation when a strong carrier is tuned in and the manual volume control is varied. Comparatively large changes in the values of  $R_3$  do not change the distortion characteristics appreciably. As shown by the curves, 2.5 watts at 15 per cent distortion is obtained at the grid-current point of the 25L6 when  $C_1 = 40 \mu\text{f}$  and  $R_3 = 50000$  ohms. Somewhat higher distortion at this output is obtained when the value of either  $C_1$  or  $R_3$  is decreased. The 6Q7 did not draw grid current during this test.

### 2. Arrangement Using 6Q7 (A-F Amplifier) and 25L6 (Self-Bias)

In the test of this arrangement, bias for the 6Q7 and 25L6 was obtained from individual self-bias resistors, as shown in Fig. 3. As in all self-bias tests described in this Note, the filter choke was connected in the positive side of the line. Hence, resistors  $R_4$  and  $R_5$  in Fig. 1 were not required.

The characteristics shown in Fig. 3 represent the same four conditions described in Arrangement 1. With  $C_1 = 40 \mu\text{f}$  and  $R_3 = 50000$  ohms, approximately 1.8 watts at 11 per cent distortion is obtained at the grid-current point of the 25L6. This should be compared to the output of 2.5 watts at

15 per cent distortion obtained with choke-bias operation for the same values of  $C_1$  and  $R_3$ . As indicated by the curves, improved performance is obtained by using the high value of input-filter condenser.

It is sometimes desirable to remove the by-pass condenser from the cathode resistor of the 25L6. With the cathode resistor not by-passed and the grid of the 25L6 operating in the negative region, power sensitivity and distortion decrease. The characteristics of the circuit shown in Fig. 3 with the 25L6 cathode resistor not by-passed are shown in Fig. 4. The corresponding curves of Figs. 3 and 4 indicate the improvement. The decrease in sensitivity is indicated in the accompanying Summary Chart.

### 3. Arrangement Using 6J7 (Biased Detector) and 25L6 (Choke Bias)

In the test of this arrangement, an r-f signal modulated 30 per cent at 400 cycles was fed to the input of a 6J7 used as a biased detector; the output of the 6J7 was resistance-coupled to a 25L6.

The circuit and operating characteristics of this arrangement are shown in Fig. 5. The bias for the 6J7 was obtained from the drop across a self-bias resistor; the screen voltage for the 6J7 was held substantially fixed by means of the resistance network shown. The bias for the 25L6 was obtained from the drop across the filter choke, as shown in Fig. 1. The distortion characteristics shown in Fig. 5 obtain for a bleeder resistor ( $R_3$ ) of 15700 ohms and for two values of  $C_1$ , i.e., 40  $\mu$ f and 24  $\mu$ f. The current through  $R_3$  equals that drawn by a 6K7 used as an r-f amplifier.

With  $C_1 = 40 \mu$ f, approximately 2.1 watts at 14 per cent distortion is obtained at the grid-current points of the 6J7 and 25L6, which occur simultaneously; the rms carrier voltage required for this output is less than 0.7 volt.

With the 25L6 choke-biased, the use of series screen feed for the 6J7 may not be desirable. If series screen feed is employed, the grid-current point of the 6J7 is reached before the grid-current point of the 25L6; consequently, in the grid-current region, the tuned circuit connected to the 6J7 is loaded by the low input resistance of the 6J7 before high output is obtained from the 25L6. Thus, the sensitivity and selectivity of the receiver are severely reduced at comparatively low outputs.

### 4. Arrangement Using 6J7 (Biased Detector) and 25L6 (Self-Bias)

The tests described in (3) were repeated for self-bias operation of the 25L6. The results for both fixed-screen and series-screen operation of the 6J7 are shown in Fig. 6. Series-screen operation of the 6J7 is permissible with a self-biased 25L6 because the grid-current points of both tubes are reached simultaneously. With  $C_1 = 40 \mu$ f and with fixed-screen operation of the 6J7, approximately 1.8 watts at 12 per cent distortion is obtained at the grid-current point of the 25L6. No grid current is drawn by the 6J7 at this output.

Operation of this circuit with the 25L6 cathode resistor not by-passed may be undesirable. Under this condition, the 6J7 draws grid current at very low outputs; thus, the tuned circuit connected to the grid of the 6J7 is loaded before the grid-current point of the 25L6 is reached.

#### 5. Arrangement Using 6F7 (I-F Amplifier, Second Detector) and 25L6

In the test of this arrangement, the pentode section of a 6F7 was connected as an i-f amplifier and the triode section was connected as a biased detector feeding a 25L6. The circuit and characteristics of this arrangement are shown in Fig. 7. The value of  $R_3$  in this test was 25000 ohms. The current through this resistor equaled that drawn by a 6A8 operating at normal voltages. When  $C_1 = 40 \mu\text{f}$  and the 25L6 obtains its bias from the choke, 2.24 watts at 14 per cent distortion is obtained at the grid-current point of the 25L6; approximately 2.75 watts is obtained at the grid-current point of the triode section of the 6F7.

When the bias for the 25L6 is obtained from a self-bias resistor, 1.84 watts at 11.1 per cent distortion is obtained at the grid-current point of the 25L6. Complete data for this operating condition are shown in Fig. 7. Operation with the 25L6 cathode resistor not by-passed may be undesirable. Under this condition of operation, grid current is drawn by the 6F7 at low outputs. Hence, selectivity and sensitivity are impaired at low outputs.

These tests were conducted with an r-f signal modulated 30 per cent at 400 cycles applied to the pentode section of the 6F7; a 465-kilocycle i-f transformer coupled the signal to the triode section of the 6F7. The rms signal voltages recorded in the Summary Chart are those which appear at the grid of the triode section. Thus, the data are independent of the impedance of the i-f transformer.

#### 6. Arrangement Using 6C5 (Biased Detector) and 25L6

The data for self- and fixed-bias operation of the 25L6 driven by a 6C5 used as a biased detector are shown in Fig. 8; the data correspond to those given for the 6F7-25L6 tube complement described in Arrangement 5 and in Fig. 7. When  $C_1 = 40 \mu\text{f}$  and bias for the 25L6 is obtained from the filter choke, approximately 2.25 watts at 15 per cent distortion is obtained at the grid-current point of the 25L6. Nearly the same results are obtained from the 6F7. Operation with the 25L6 cathode resistor not by-passed is undesirable with this tube complement, because of the low output at which grid current flows. The current through  $R_3 = 9750$  ohms corresponds to that drawn by a 6A8 and 6K7 operating at normal voltages.

#### Conclusion

A summary of the data presented in this Note appears in the accompanying Summary Chart. It is convenient to refer to this Chart for data at the grid-current point of the 25L6; detailed operating information is available from the curves. The 25L6 can furnish its rated output in a variety of practical circuits, each suitable for use in low-cost a-c/d-c receivers.

## SUMMARY CHART

Tube Complement	Purpose	Bias Data <sup>1</sup> (Zero Signal)	Screen Data (Zero Signal)	Arrangement No. <sup>2</sup>	Fig. No.	Output Voltage of Power Unit		25L6 Cathode Milliamperes		Total Rectifier Milliamperes		Signal Input <sup>3</sup> for indicated power output	Power Sensitivity <sup>4</sup>	Power Output <sup>5</sup> (Watts)	Total Harmonic Distortion - %
						Zero Signal	Max. Signal	Zero Signal	Max. Signal	Zero Signal	Max. Signal				
6Q7 25L6	A-F Amplifier Output	F 1.1 Volts	-	1	2	111	108.5	51	56.1	94	98	0.87	3300	2.5	15
		F 7.5 Volts	To B+			111	109	48	51.2	91	93.5	0.53	6300	1.8	11.1
6Q7 25L6	A-F Amplifier Output	S 4400 Ohms	-	2	3	111	109	48	51.2	91	95	1.13	1300	1.65	9.5
		S 150 Ohms	To B+			110	108.5	48	51.3	95.5	98	0.67	4700	2.1	14.3
6J7 25L6	Biased Detector Output	S 5800 Ohms	Fixed	3	5	108	106	48	52.5	99	103	0.61	4800	1.8	12
		F 7.4 Volts	To B+			109	107	47.5	50.6	99	101.5	0.55	5800	1.75	11.5
6J7 25L6	Biased Detector Output	S 5800 Ohms	Fixed	4	6	110	108.5	48	51.3	95.5	98	0.67	4700	2.1	14.3
		S 150 Ohms	To B+			107.5	106	49	54	100	104	6.7	50	2.24	14
6F7 25L6	I-F Amplifier Biased Detector Output	S See Fig. 7	-	5	7	107.5	106	49	54	100	104	6.7	50	2.24	14
		F 7.3 Volts	To B+			108	107	47	50	98	100.5	6	51	1.84	11.1
6C5 25L6	Biased Detector Output	S 0.05 Meg.	-	6	8	106.5	104	46.5	51.6	101.5	105.5	2.25	440	2.26	15.2
		F 7.3 Volts	To B+			107	105	46.8	52	102	104	1.9	500	1.82	12
6C5 25L6	Biased Detector Output	S 0.05 Meg.	-	6	8	107	105	46.8	52	102	104	1.9	500	1.82	12
		S 150 Ohms	To B+												

<sup>1</sup> F = choke bias (see Fig. 1); S = self-bias.

<sup>2</sup> Highest value of bleeder resistor is assumed.

<sup>3</sup> See figures for details.

<sup>4</sup> RMS carrier voltage input to detector, modulated 30% at 400 cycles. In the case of the 6Q7, linear diode detection is assumed. In the case of the 6F7, values are input to triode (detector) section.

<sup>5</sup> Power Sensitivity =  $\rho = \text{Milliwatts Output} / (\text{RMS Input Volts to Detector})^2$   
Values in chart are computed on basis of 30% modulation.

<sup>6</sup> At grid-current point of 25L6.

\* Not by-passed.

AVERAGE PLATE CHARACTERISTICS

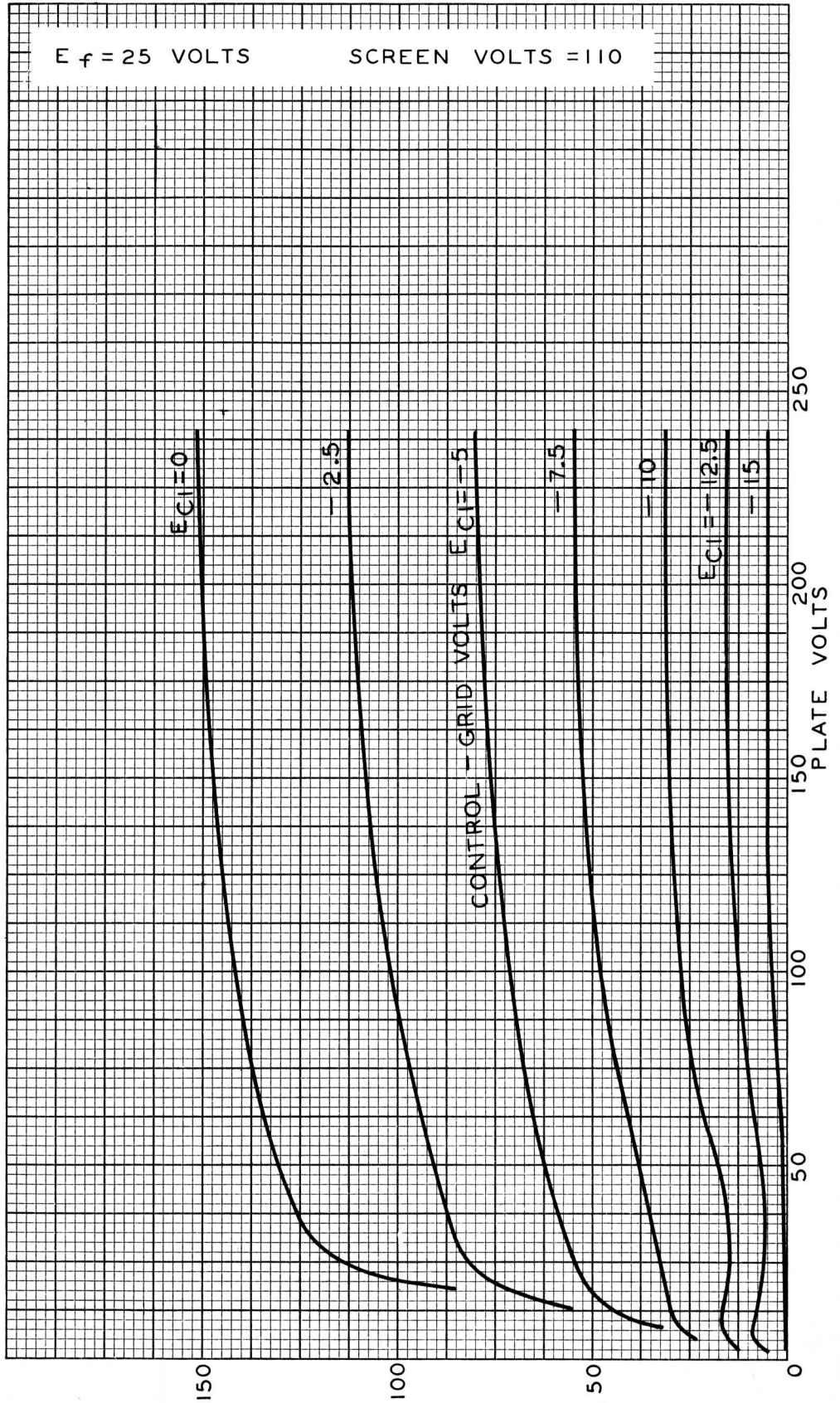

TYPICAL A-C/D-C POWER-SUPPLY UNIT

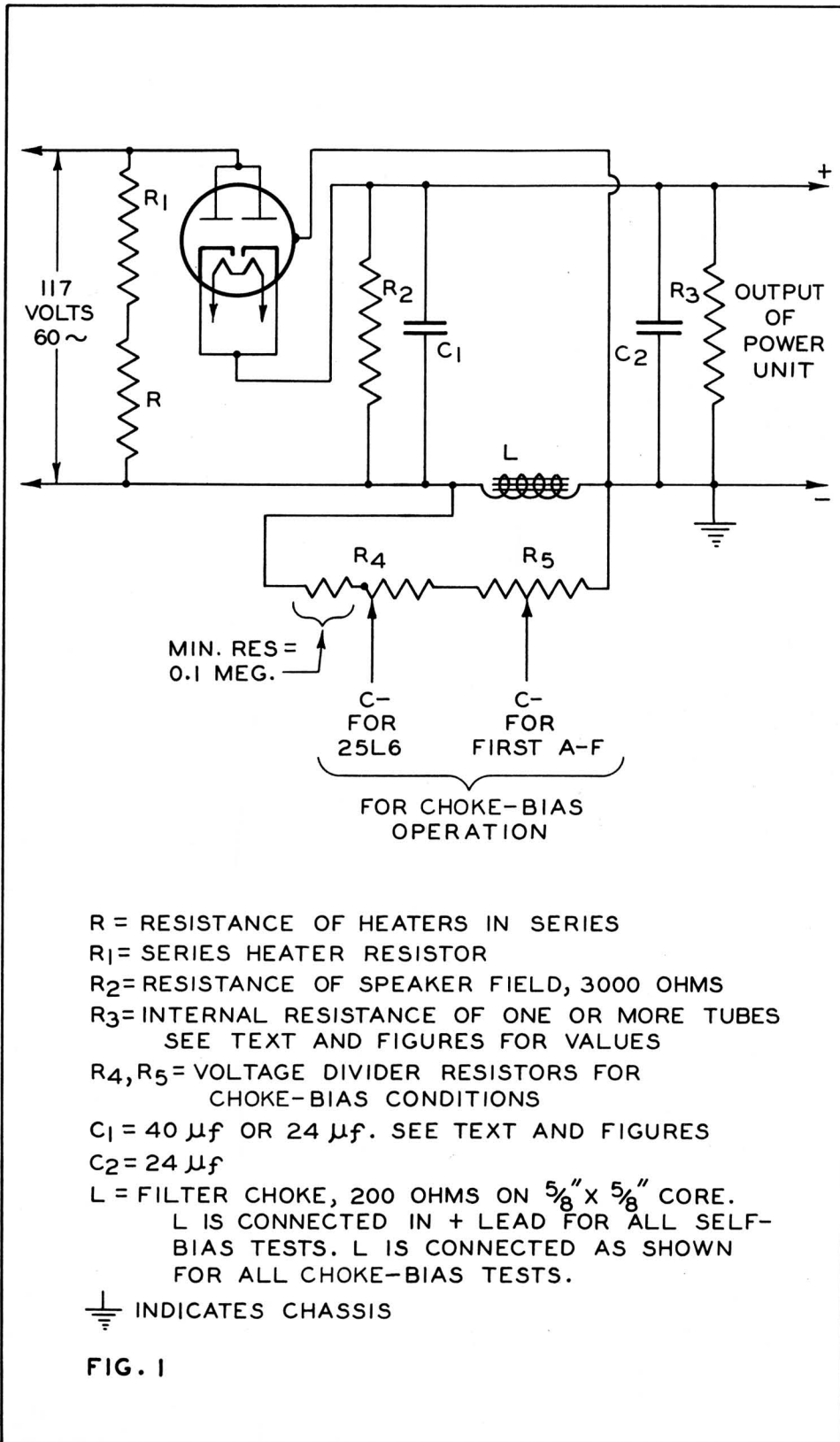

R = RESISTANCE OF HEATERS IN SERIES  
 R<sub>1</sub> = SERIES HEATER RESISTOR  
 R<sub>2</sub> = RESISTANCE OF SPEAKER FIELD, 3000 OHMS  
 R<sub>3</sub> = INTERNAL RESISTANCE OF ONE OR MORE TUBES  
 SEE TEXT AND FIGURES FOR VALUES  
 R<sub>4</sub>, R<sub>5</sub> = VOLTAGE DIVIDER RESISTORS FOR  
 CHOKE-BIAS CONDITIONS  
 C<sub>1</sub> = 40 μf OR 24 μf. SEE TEXT AND FIGURES  
 C<sub>2</sub> = 24 μf  
 L = FILTER CHOKE, 200 OHMS ON 5/8" x 5/8" CORE.  
 L IS CONNECTED IN + LEAD FOR ALL SELF-  
 BIAS TESTS. L IS CONNECTED AS SHOWN  
 FOR ALL CHOKE-BIAS TESTS.  
 INDICATES CHASSIS

FIG. 1

The license extended to the purchaser of tubes appears in the License Notice accompanying them. Information contained herein is furnished without assuming any obligations.



RCA-6Q7, RCA-25L6

TYPICAL OPERATION CHARACTERISTICS WITH CHOKE BIAS

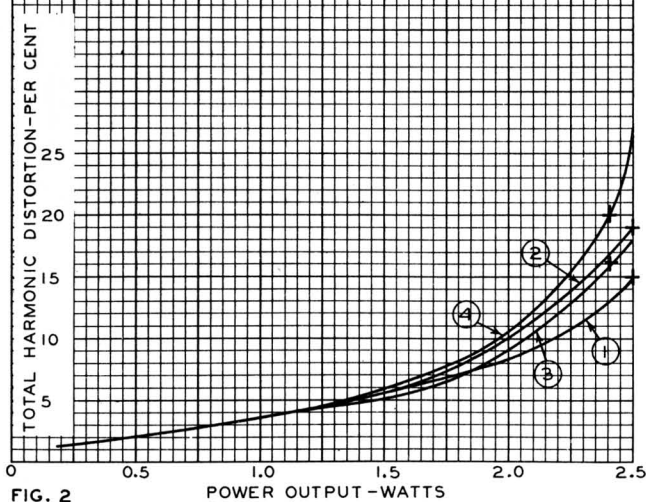
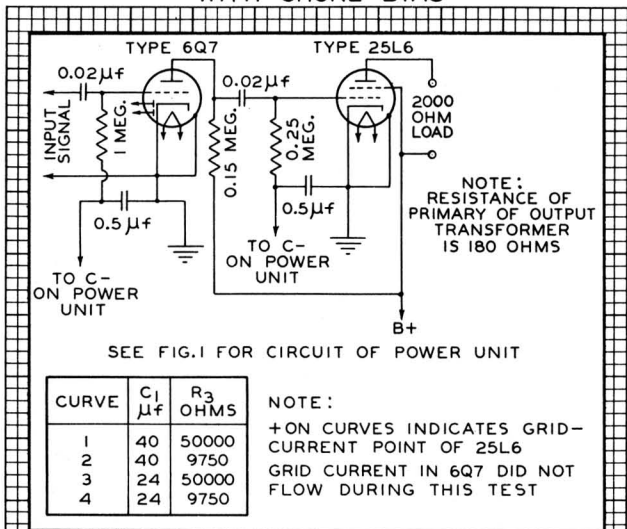

FIG. 2

FEB. 15, 1937

RCA RADIOTRON DIVISION  
RCA MANUFACTURING COMPANY, INC.

92C-4734



RCA-6Q7, RCA-25L6

TYPICAL OPERATION CHARACTERISTICS WITH SELF-BIAS

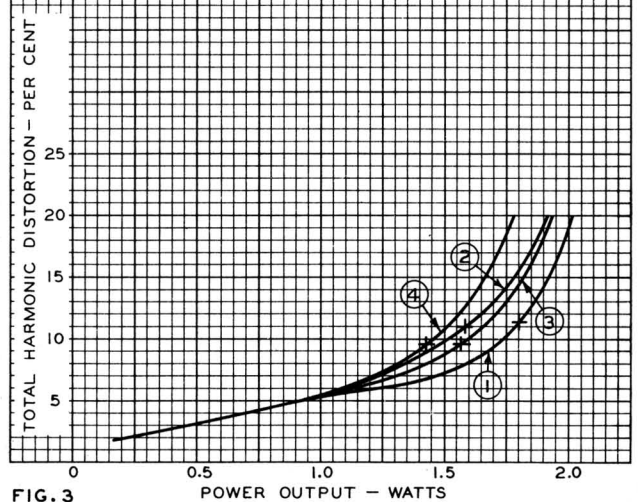
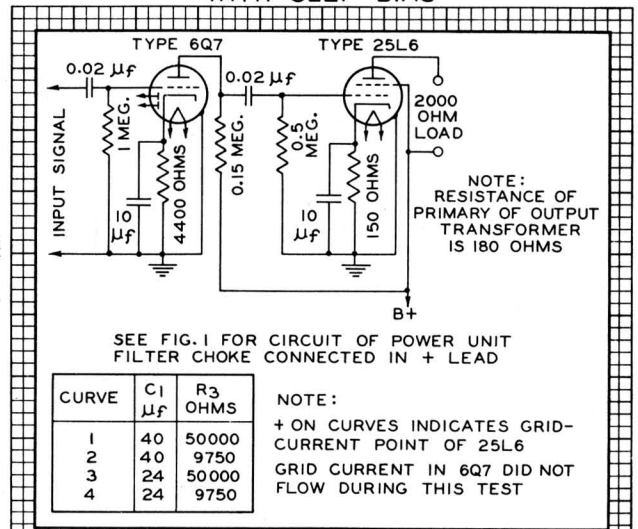

FIG. 3

FEB. 15, 1937

RCA RADIOTRON DIVISION  
RCA MANUFACTURING COMPANY, INC.

92C-4735





RCA-6Q7, RCA-25L6

TYPICAL OPERATION CHARACTERISTICS WITH SELF-BIAS

CIRCUIT: SAME AS IN FIG.3, EXCEPT THAT 25L6 CATHODE-RESISTOR BY-PASS CONDENSER IS REMOVED. SEE FIG.1 FOR CIRCUIT OF POWER UNIT. FILTER CHOKE CONNECTED IN + LEAD.

CURVE	C1 μf	R3 OHMS
1	40	50000
2	40	9750
3	24	50000
4	24	9750

NOTE:  
+ ON CURVES INDICATES GRID-CURRENT POINT OF 25L6  
○ ON CURVES INDICATES GRID-CURRENT POINT OF 6Q7

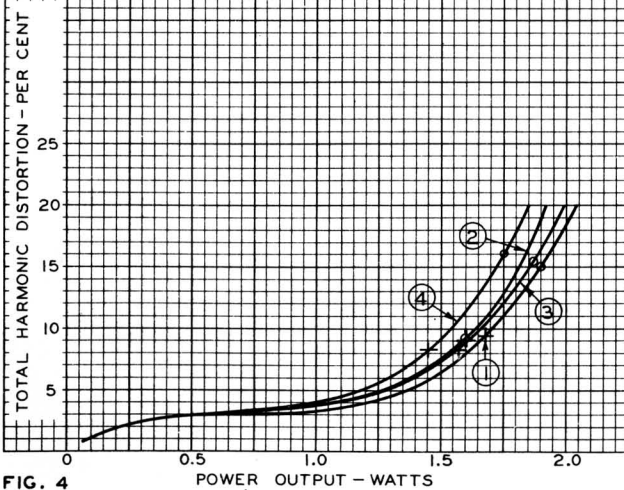

FIG. 4 POWER OUTPUT - WATTS

FEB. 17, 1937

RCA RADIOTRON DIVISION  
RCA MANUFACTURING COMPANY, INC.

92C-4736



RCA-6J7, RCA-25L6

TYPICAL OPERATION CHARACTERISTICS WITH CHOKE-BIASED 25L6

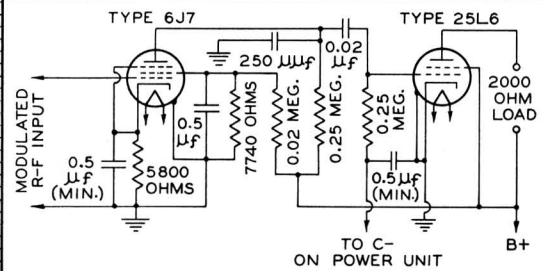

SEE FIG. 1 FOR CIRCUIT OF POWER UNIT

NOTE: RESISTANCE OF PRIMARY OF OUTPUT TRANSFORMER IS 180 OHMS

CURVE	C1 μf	R3 OHMS
1	40	15700
2	24	15700

NOTE: CURVES TERMINATE AT GRID-CURRENT POINT OF 6J7 AND 25L6; THESE POINTS OCCUR SIMULTANEOUSLY.

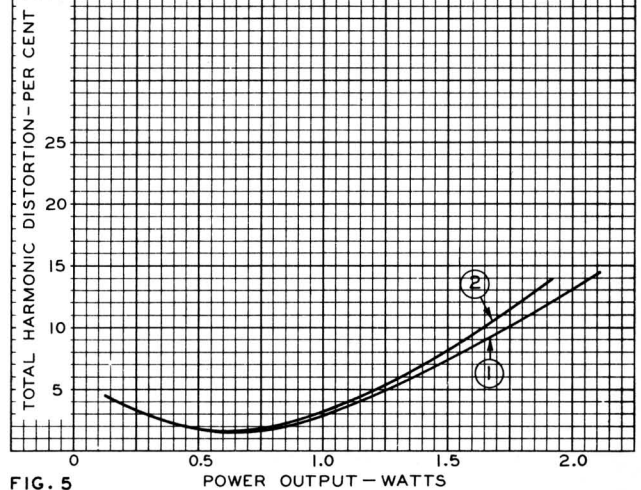

FIG. 5 POWER OUTPUT - WATTS

FEB. 17, 1937

RCA RADIOTRON DIVISION  
RCA MANUFACTURING COMPANY, INC.

92C-4737

TYPICAL OPERATION CHARACTERISTICS  
WITH SELF-BIASED 25L6

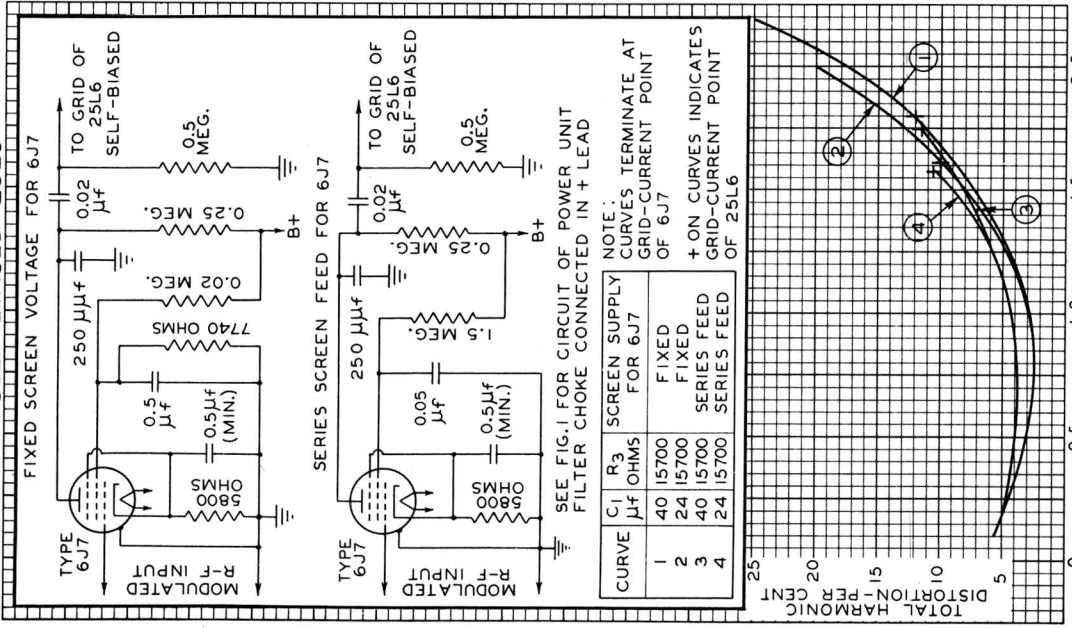

FIG. 6  
FEB. 19, 1937

TYPICAL OPERATION CHARACTERISTICS  
WITH CHOKE-OR SELF-BIASED 25L6

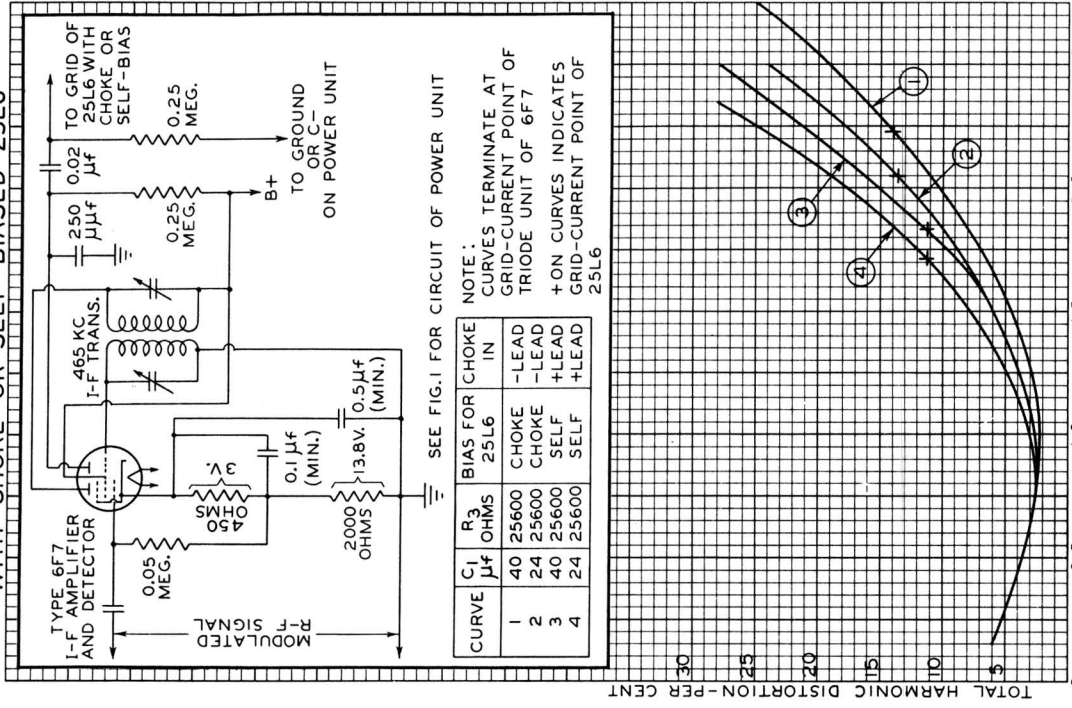

FIG. 7  
FEB. 19, 1937

RCA-6C5, RCA-25L6

TYPICAL OPERATION CHARACTERISTICS  
WITH CHOKE - OR SELF-BIASED 25L6

